

Escalator Machine

***oms*Hypodrive EC 2 - 25**



Operating and Maintenance Manual



List of Contents

	Page
1 FOREWORD	3
2 GENERAL	4
3 BASIC MACHINE	5
3.1 Technical data	5
3.2 Modules and built on parts	5
3.3 Alternative equipment	5
3.4 Spare parts	6
3.5 Gear versions and fitting locations	6
4 COMMISSIONING	7
4.1 Assembly	7
5 SERVICE AND MAINTENANCE	9
5.1 Gear oil	9
5.2 Servicing the brakes	11
5.3 Brakes	13
5.4 Replacing the motor	16
5.5 Replacing the elastic coupling ring	16
5.6 Replacing the bearing pot for the hypoid pinion	17
5.7 Replacing the motor bearing on side B	18
5.8 Adjusting the braking function sensor	20
5.9 Adjusting the break lining wear control	21
5.10 Adjusting the hood-type switch	22
6 MISCELLANEOUS	23
6.1 Storage	23
6.2 Transport	24
7 APPENDIX	25
A OMS technical data – escalator machine EC 2 - 25	26
B OMS dimensioned drawing – escalator machine EC 2 - 25	27
C Electrical connections	28
D Pin assignment – Wieland connector	29
E Declarations of conformity	30
F EU-safety data sheet SYNTHESO® D/EP-Oils	31



1 Foreword

The OMS escalator machine EC 2 -25 is used as the drive for escalator and passenger conveyors (moving pavement, travelators) and is designed for use inside a confined space (e.g. in a state authority building). Its use in any other way requires release by OMS.

The OMS escalator machine is a high-performance drive unit, consisting of several modules with different tasks. The design of the motor is suitable for operation with frequency converters.

Please read this operating and maintenance thoroughly. It will help you to avoid possible malfunctions and discrepancies during the commissioning and operation of the machine.

The safety measures and regulations for the commissioning and operation of escalator machines comply with DIN EN 115 and DIN EN 292 Part 1 and 2, each in their respective latest version.

The OMS escalator machine may only be used in a technically perfect condition and the working capacity confirmed by OMS.

Should the machine have been damaged during transport or if a defect is identified during the commissioning of the machine, please inform OMS immediately giving details of the defect or damage.

If water damage exists, please contact OMS.

The decision, whether to repairs can be carried out on site and the machine still be used should only be made after consultation with and release from OMS. If necessary the machine must be returned to OMS in its original packaging.

Therefore, please keep the packaging material until after commissioning.

If changes, become recognisable during the machine's service life, e.g. due to wear, aging, etc., they should be immediately corrected according to this operating and maintenance manual.

The gears may only be opened in the factory by OMS, otherwise all warranty and guarantee claims expire.

Should the machine not be used until a later date, measures must be taken to conserve the machine (see Chapter6 Page 23).

2 General

The machine requires low maintenance.

The very high, 96%, efficiency of the gears ensures that the power losses are reduced so far that built on parts and surrounding mechanical and electronic elements are only subjected to low heat loads. This has a favourable influence on wear and temperature-induced aging of the components.

Therefore topping up the gears with oil is called **long-term lubrication**.

For average ambient temperatures of approx. 30°C and under continuous operating methods the oil can be used for up to 30,000 operating hours. Apart from the usual checks, the lubricating properties of the oil should be examined every 2 – 3 years (see Chapter 5).

The OMS escalator machine consists of few modules and built-on parts, which if necessary can be completely replaced.

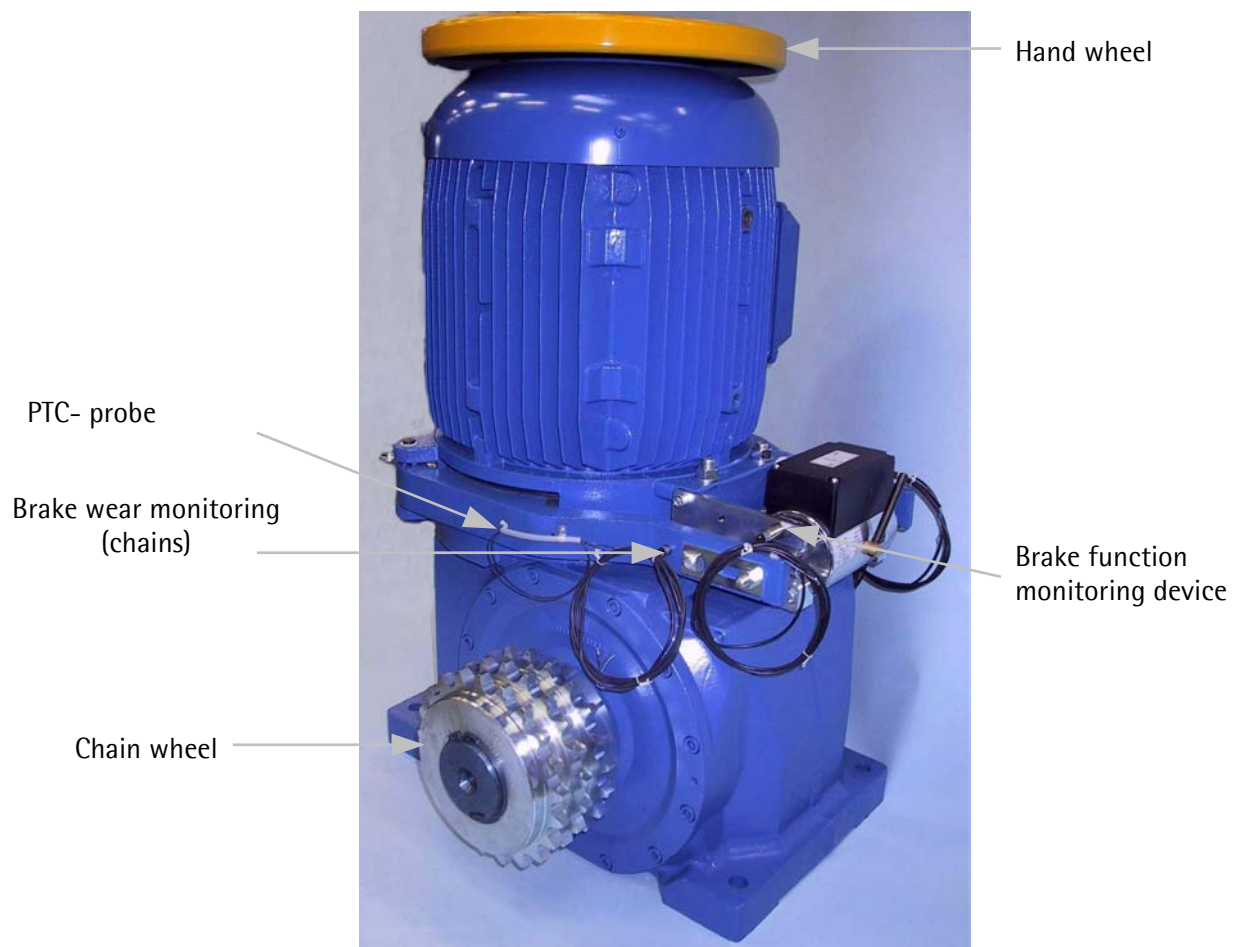

Fig. 1: Design of the OMS escalator machine EC 2 - 25



3 Basic Machine

3.1 Technical data

Please refer to the Appendix for details of the OMS escalator machine's working capacity, sheet:
„Technical data for escalator machine EC 2 - 25“.

All dimensions and connecting dimensions for the OMS escalator machine are given in the Appendix:
„Dimensioned drawing of the escalator machine EC 2 - 25“.

3.2 Modules and built on parts

The OMS escalator machine EC 2 - 25 consists of:

- Gears, complete
- Motor, complete (with hand wheel and motor cover)
- Brake system, complete (including brake drum and coupling)
- Sprocket wheel
- Function monitoring devices
 - Brake function monitoring (optional)
 - Brake lining wear monitoring (optional)
 - Brake lining temperature monitoring (optional)
- Safety devices
 - Speed sensors (NRD monitoring) (optional)
 - Over/underspeed monitoring (optional)
 - Stopping distance monitoring (optional)
 - Fan cover switch (safety circuit) (optional)
 - Frequency scaler (5:1) with NAMUR interface (optional)

3.3 Alternative equipment

The escalator machines can also be fitted with the following alternative components:

Motor selection

Standard-features:

- Terminal box (140x140) with metric thread for BG 160
- Terminal box (224x224) with metric thread for BG 225
- 3 Winding earthing contact (bimetal opener)
- Colour: gentian blue RAL 5010,
- Motor cover slit and secured with wing screws (can be pulled off)
- Fixing facility for hand wheel safety switch
- Motor shaft and BS end shield provided for magnetic encoders (9 tapped holes M4)
- 60 Hz-Motors 6 pole (11,7 / 15 / 18,5 or 22kW)
- Brake drum and hand wheel fan fitted

3.4 Spare parts

The following components can be exchanged:

- Gear housing
 - Hypoid bearing pot, complete
 - Coupling
 - Sprocket wheel
- Motor, complete (incl. motor coupling claw, elast. coupling ring)
 - Bearings
 - Hand wheel
- Brake
 - Brake releasing magnet, individual (in the sizes O 30, O 31(single circuit) – O 32, O 33 dual circuit)
 - Brake lever – pair with brake lining
 - Spring single circuit/ springs – dual circuit
 - Brake lever bolts
- Sensor technology
 - Over and underspeed controls
 - Brake lining wear control
 - Braking function controls
 - Hood-type switch

3.5 Gear versions and fitting locations

The type of construction used for the OMS escalator machine EC 2 - 25 enables the Motor terminal box installations to be positioned in two different fitting locations:

Position A – Brakes to the right next to the sprocket wheel (view onto the sprocket wheel)

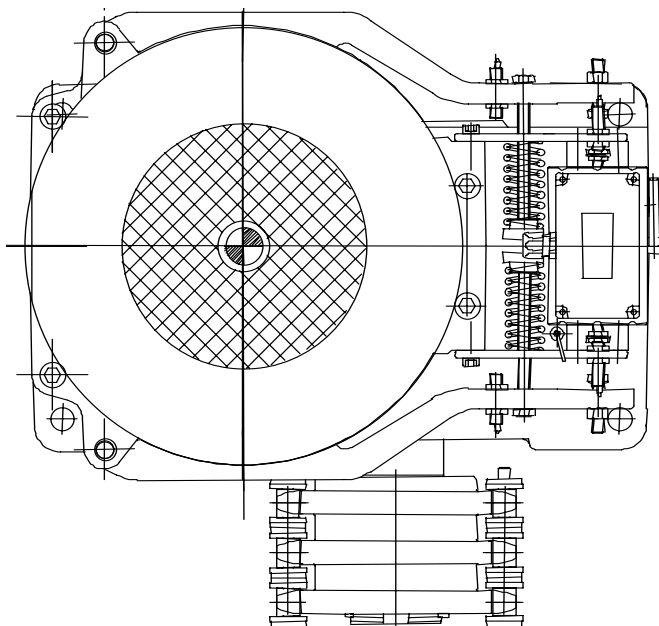

Fig. 2

4 Commissioning

4.1 Assembly

4.1.1 Escalator machine complete



Before commissioning

Replace the labelled **screw plug** on the gear housing with the **dipstick** supplied, see Fig.3 - 4). Please keep the screw plug in a safe place, easy to find for possible subsequent transport of the machine.

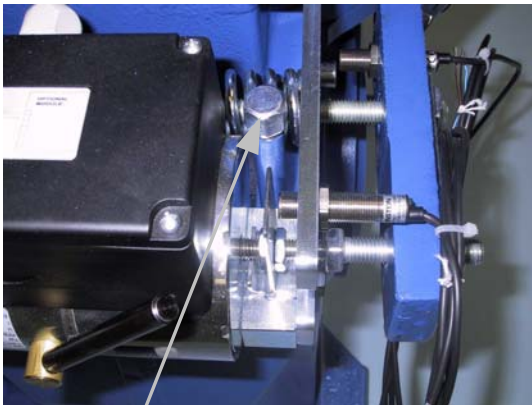

Fig. 3

Screw plug

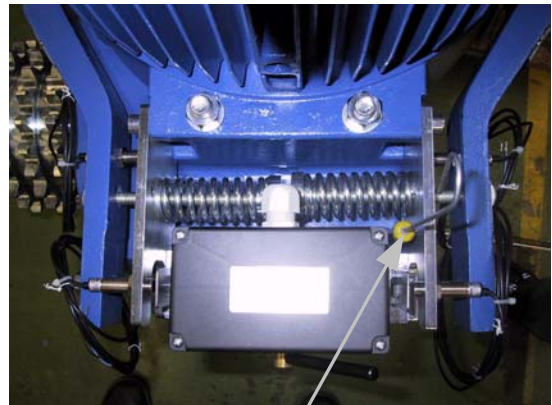

Fig. 4

Oil dipstick

Note:

The gears are sealed oil-tight for transport. With the screw plug the gears do not have any ventilation. If it is started up while being sealed in this way, an overpressure can be created in the housing, with the possible consequence of leaks and oil leaks at the shaft-sealing ring. The dipstick does not represent a seal for the gears.

Electrical connection



Only trained and qualified personnel may open the terminal box on the motor and the supply voltage connection or carry out maintenance or repairs to electrical parts of the machine.

Switch off the mains switch beforehand and secure it against being accidentally switched back on!

Note:

The machine's electrical equipment has been designed in compliance with the general technical specifications of EN 60 204 - 1.

Procedure:

1. Motor :

The connection to the power supply is carried out according to the circuit diagram in the motor's terminal box (for details see the terminal diagram for the motor in the Appendix).

If another cable output is required as the specified direction, the terminal box can be rotated by undoing the internal screws. Carefully undo and fasten the thin temperature monitoring cable.

2. Brake magnet :

The brake magnet (dual circuit double lift split magnet) must be connected according to the various requirements (see connection of the brake magnet to the power supply in the Appendix). Supply voltage generally 230V AC ($\pm 10\%$ max).

- a) For a single circuit braking system, both circuits of the magnet (O-30) are connected via a control module.
- b) For a dual-circuit braking system both circuits are connected via a control module with over excitation (O-31) or each connected via separate control modules (O-32, O-33).

5 Service and Maintenance



Before starting the maintenance work the main power switch must be switched off and secured against being accidentally switched back on!

5.1 Gear oil

5.1.1 Check the oil level

During each service.

- At the dipstick: Oil level between the marks

5.1.2 Check the condition of the oil

Always check the condition of the oil at regular intervals.

Check:

- Check the oil for discoloration, pull out the dipstick and allow a drop of oil to fall on the oil test card.
- Oil colour light yellow to mid-brown: Condition of the oil is good to still usable;
- Oil colour mid-brown to dark-brown: **Change oil immediately.**
- Oil colour dark-brown to black: **Oil cannot be used**



5.1.3 Oil change

Please proceed as follows if an oil change is necessary:

1. Place a suitable container beneath the oil drain plug on the bottom of the gears. The volume of oil is approx. 13 l.
2. Carefully open the oil drain plug.
3. After all the oil has drained, refasten the oil drain hole.
4. Fill the oil by pouring it into the dipstick opening.
5. Please note the filled level (see 5.1.1).
6. Only use the specified oil grade:

Klüber Syntheso D 220 EP Quantity: 13 l (never mix with other grades of oil!)
(Only use other oil grades after consulting OMS)

7. Close the filling opening with the dipstick.



Oil drain plug

Fig. 5

5.1.4 General comments:

The loss of lubricating properties and the dark brown to black discoloration of the oil result after long maintenance intervals, due to particles or dirt collecting in the oil bath, due to moisture in the gear housing, high ambient temperature and the resulting temperature in the machine room. Please note: These conditions accelerate the end of the oil lubricating properties. Therefore: In case of doubt change the oil.



Any oil that escapes during an oil change or as the result of a leak must be removed immediately.

Used synthetic oil that has been replaced is special waste!

5.2 Servicing the brakes

5.2.1 Check: The brake lever for easy movement

During the usual maintenance intervals the brake levers of the escalator equipment must be checked for easy movement. To do this, each individual brake lever must be opened as described under 5.3.4 (check the two brake circuits). The brake lever must close again with easy movement. If necessary the brake lever joint pin must be tightened (see 5.3.3) and regreased before being refitted.

5.2.2 Check: Air clearance and brake lining wear

a) Air clearance:



The air clearance must not be less than 1.0 mm.

As soon as the air clearance reaches 1 mm it must be adjusted back to maximum 1.5 mm

(See Section 5.3.2 and Fig.9).

Procedure:

1. Press back the magnetic tappet and measure the clearance between the tappet and pressure screw (Fig. 9).
2. To adjust, undo the lock nut, turn the pressure screw and retighten the lock nut. Set value $S=1.5$ mm.
3. After adjusting the clearance open the brake mechanically using the air lever on the magnet and check electrically via the plant controls



If the air clearance can no longer be adjusted because the screw head is in contact with the brake lever, both brake levers must be replaced with new linings!

b) Brake lining wear:

The amount of brake lining wear determines the position of the brake lever. With increasing brake lining wear the brake lever approaches the inside of the magnet.

The brake lining area in the engagement should be $\geq 70\%$ of the total area.

Check for brake lining wear:

If the minimum spacing at a brake lever has been reached, both brake levers must be replaced with relined levers.

5.2.3 Replace the brake lever

- **You must always replace both brake levers!**
- The brake levers on each side are always replaced one after the other.
- To replace the brake lever, the compression spring must be removed along with the locked pressure washer and the clamping bolt.
- Pull out the splint.
- Push up the joint pin (with flat screwdriver under the bolt head) and pull out.
- Lift out the lever to the side, at the same time removing the intermediate washers.
- A lever with new brake linings is fitted in the reverse order.
- Do not forget the intermediate washers!
- Adjust the brakes, and check braking capacity, as under 5.3.2

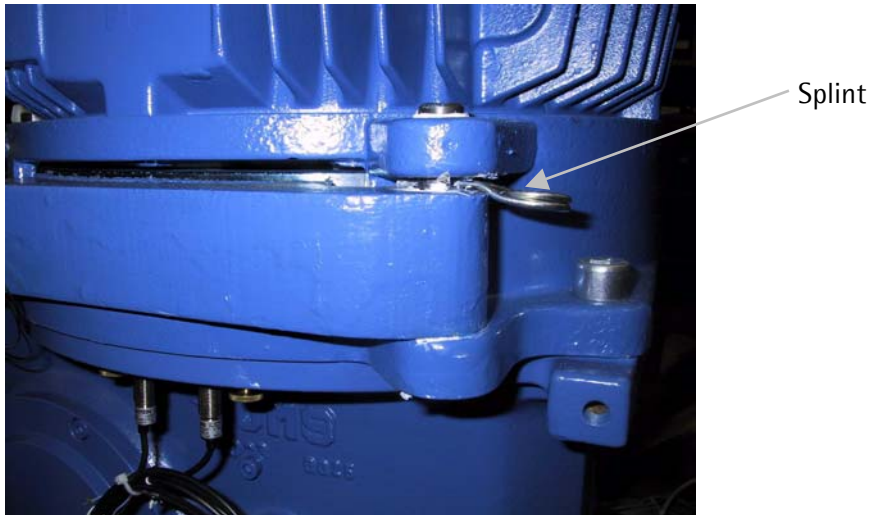

Fig. 6



When new brake linings are fitted the required braking moment is not reached until the brakes have been briefly pressed with the selected spring bias!

5.3 Brakes

5.3.1 Adjusting the brakes

Depending on the nominal moment required for the motor, magnets with the appropriate lifting force and compression springs with the relevant stiffness are specified in the factory. In the dual circuit brakes the magnet is controlled on opening with brief excitation, i.e. with increased lifting force.

To compensate for possible brake lining wear and reliable check of the wear, an air clearance of 1.5 mm is preset between the magnetic tappets and the respective pressure screws. To check and adjust the air clearance see Section 5.3.2.

Please check the function of the brakes before commissioning the escalator. If the preset braking moment does not match the operating conditions you can adjust it.

5.3.2 Adjusting the brake moment of the dual circuit braking system:

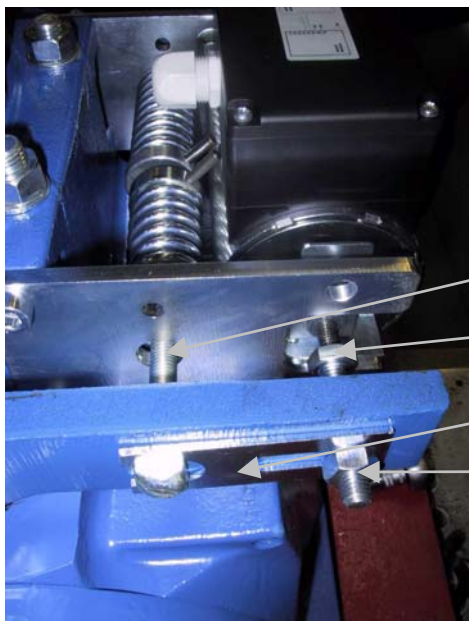

Pressure screw

Hexagon bolt M12x60

Safety cover

Hexagon nut M12

Fig. 7

1. With the brake disengaged, loosen the frontal nut M12 on the hexagon bolt M12x60.
2. Pull the safety cover back. The pre set brake spring pressure can be adjusted by turning the brake spring pressure screw (Turning clockwise increases the pre set pressure).

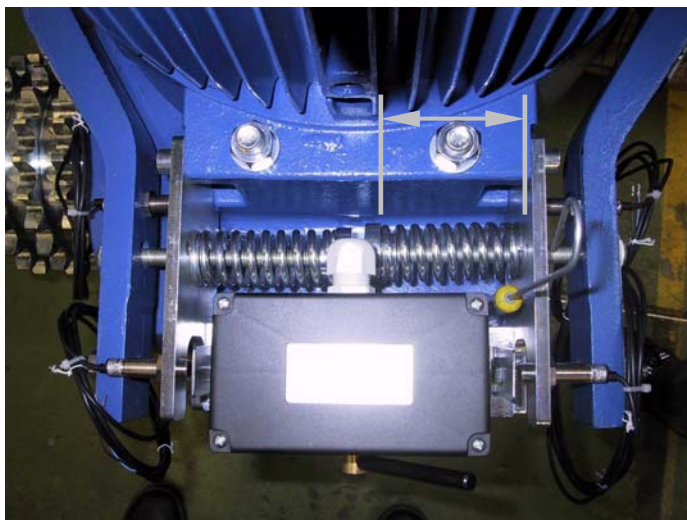

Fig. 8

3. Spring pressure preset of spring length L between the two surfaces on 88mm, is adjusted during the TÜV field inspection (see Fig. 8).
4. Once the required value has been achieved, move the safety cover forward into position over the head of the screw. If required carefully tighten the screw further.
5. Tighten the hexagon nut M12 and use the air lever of the magnet to check whether the required air clearance (return stroke) is still available. If necessary reset to the required air clearance of 1.5 mm by adjusting the pressure screw in the brake lever.
6. Check whether the brake magnet completely opens, mechanically with the central air lever and electrically via the plant controls.

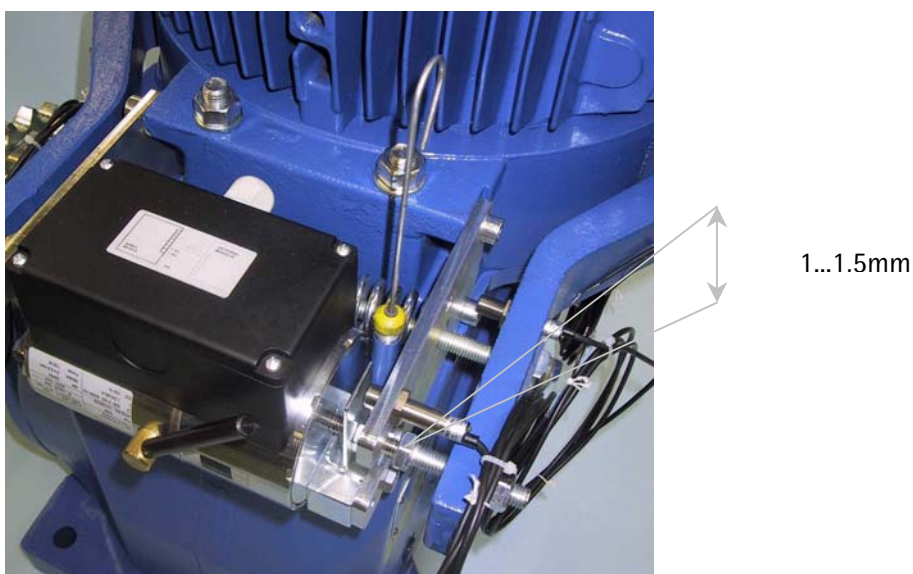

Fig. 9



5.3.3 Checking the two brake circuits:

Note: The procedure for the brake acceptance inspection within the scope of the escalator acceptance inspection is not described here in detail. Please note the required safety regulations.

a) If the machine is accessible

If the machine is accessible in an operations room, you can individually open each brake lever to the side with the aid of a tyre lever (heavy screwdriver) and check the simple holding torque of the respective other brake lever.

b) Separate electrical remote control: To check the simple holding torque of each braking circuit, the brake levers can be individually controlled separately by the two existing magnetic coils. This requires a Type O 33 magnet.



5.4 Replacing the motor

If it is necessary to replace the motor after a long service life or if the motor is defective, an elastic coupling ring is supplied for the replacement.

- Stop the escalator and secure it against accidentally starting up again.
- Release the brakes by pressing the manual lever on the brake magnet and fix the lever with a wooden wedge to prevent it from moving
- Remove the switch (hood-type switch, controller for overspeed and temperature monitoring) from the motor.
- The motor connection cable on the motor must not be removed. It must only be disconnected at the contactor.
- Remove the 2 motor threaded fasteners and the 2 nuts M16.
- Raise the motor using a rope and the eye bolts to be fixed to the side of the motor.
- Replace the elastic coupling ring; at the same time clean the claw coupling e.g. by blowing the dirt out.
- To replace the motor mark a coupling claw on the motor with a gap in the gear coupling and in this way carefully guide the coupling claws into each other while putting down the motor.
- Tighten the fixing screws several times by tightening the diagonally opposite screws one after the other. (Torque approx. **195 Nm**)
- Fit the components in the reverse order.
- Connect all the electric switches and systems.
- Check the electric connections and the correct rotational direction of the motor.

5.5 Replacing the elastic coupling ring

A claw coupling with an elastic coupling ring is located between the motor and the gears. The coupling ring is made of polyurethane material, essentially moisture and heat resistant. However, should this coupling range age due to unfavourable ambient conditions, this can be recognised by increased rotation clearance in the motor shaft when the brakes are closed (locked).

5.6 Replacing the bearing pot for the hypoid pinion

Assembly sequence:

1. Dismantling the motor
 - See section 5.4
 - Raise the motor using the lifting gear and place it on square timbers (the motor must not be put down with the brake drum on the floor)
2. Dismantle the bearing pot
 - Remove the coupling halves using a two-arm pull-off device



Fig. 10

- Twist out the fixing screws M10 x 30 and pull out the bearing pot by screwing in the two jackscrews in the jackscrew holes from the gearbox. Caution, do not allow them to fall into the gears!
- Place the shim rings supplied on the gear housing.
- Insert the bearing pot in the marked position in the housing, (use the oil drill holes in the housing and in the bearing pot)
- Wet the screws with a locking agent, screw in the screws and tighten them uniformly with 30Nm torque by fastening diagonally opposite screws one after the other.
- Heat the coupling halves and place them on the hypoid tappet shaft..
- With pin log DIN 1481 Ø12 x 16 dowel
- Insert the coupling buffer ring (Caution! Leave the heated coupling halves to cool)
- Lower the motor and fasten.
- Place the brakes in their initial position
- Release the braked escalator
- Carry out a test run

5.7 Replacing the motor bearing on side B

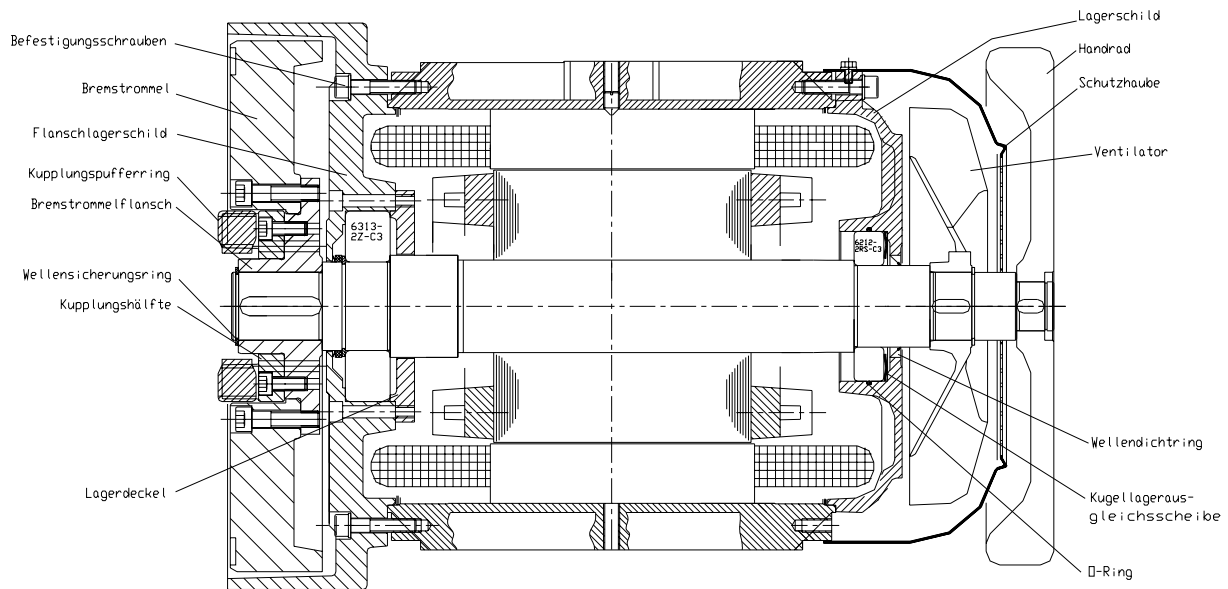

Fig. 11

5.7.1 B – side motor bearings

Dismantling sequence:

1. Pull the hand wheel off the rotor shaft. Use the pull-off device with axial support on the rotor shaft.
2. Unscrew the wing screws
3. Pull off the fan hood axially
4. Remove the locking ring
5. Pull the fan off the rotor shaft. Use the pull-off device with axial support on the rotor shaft.
6. Remove the feather key
7. Remove the pole ring and encoder pick-ups
8. Unscrew and remove the fixing screws of the flanged end shield
9. Undo the axial flanged end shield from the stator housing; remove the ball bearing equaliser rings from the ball bearing seat of the BS end shield.
10. Pull off the B-side bearings from the rotor shaft using the pull-off device supported on the end of the shaft.



Assembly instructions:

Important information for the assembly

Assembling rolling contact bearings

The installation of rolling contact bearings requires special care and skill. The information provided by the bearings manufacturer for the installation and dismantling of rolling contact bearings must be observed complied with. In particular, the running rings, cages, rollers or cover discs must never be directly hit because this damages or even destroys the bearings. The installation forces must not be fed via the roller. The centre holes with thread M12 at the ends of the shaft enable the bearings to be correctly tightened on their seat (see also the information about assembly aids). The bearing seat area on the shaft and in the housing must be lightly greased.

Assembly of the ventilator

When assembling a ventilator the rotor shaft must be axially supported, so that neither the installation forces nor any impact acts on the bearings, which could lead to damage or destruction of the bearings. The centre holes at the ends of the shafts enable the ventilator to be properly tightened on its seat (see also the information about assembly aids).

Assembly aids for roller contact bearings and ventilators

The rotor shaft has a centre hole to DIN 332, form DR with thread M 12 at both ends of the shaft. The thread is used to hold a threaded rod of appropriate length, to be able to assembly the rolling contact bearings and ventilators using a compression washer and section of pipe as well as a nut.

Damaged parts must be replaced. Only use original spare parts!

Assembly of the B-side motor bearings

1. Press the B-side bearings on the bearing seat of the rotor shaft using a section of pipe, which is placed on the inner ring (see the assembly information).
2. Insert the ball bearings disc in the bearing seat of the BS end shield and six with grease from the grease depot, to prevent it from falling out of the bearing seat during assembly.
3. Place the flanged end shield with the inserted axial shaft-sealing ring on the rotor shaft with the fitted bearings.
4. Insert and tighten the fixing screws
After the screws have been tightened, hold the rotor at the end of the shaft and turn it to check its mobility in the bearings.
5. Fit the pole ring and pickup.
6. Insert the locking ring and feather key in the rotor shaft.
7. Fit the ventilator to the rotor shaft. The assembly notes for ventilators given above must be observed.
8. Put on the fan hood. Ensure that the slits in the safety hood interlock into the grooves of the rubber bushings on the wing screws.
9. Firmly tighten the wing screws.
10. Assembly the hand wheel on the rotor shaft.

5.8 Adjusting the braking function sensor

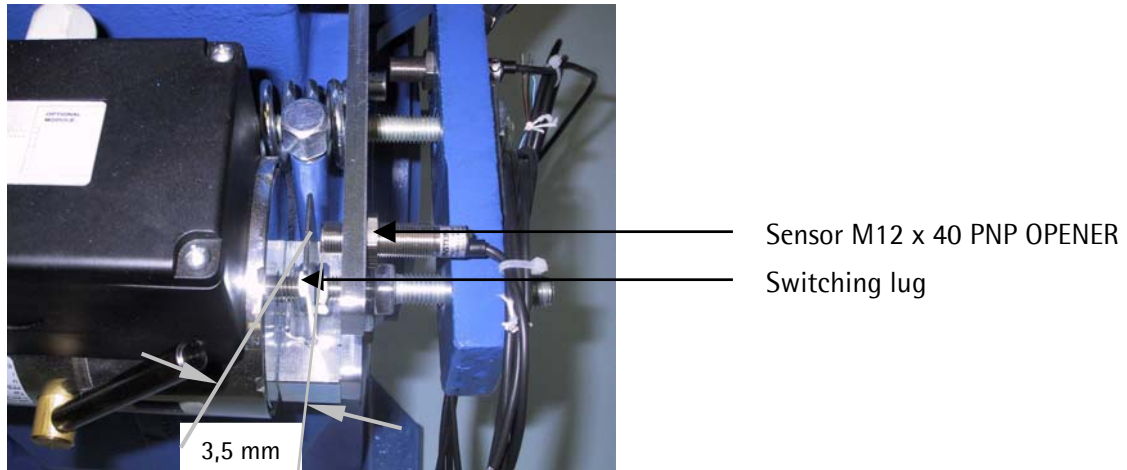

Fig. 12

- The switching lug must be fitted onto the thread of the brake magnet tappet.
- The sensor must be installed in the front drill hole with an air clearance of 1.3mm between the sensor and brake magnet housing. The sensors must be adjusted while the brakes are closed.

Information about the inductive brake function sensor:

Design sensing distance: 2,0mm

Initial function – electric circuit by opened brake closed

5.9 Adjusting the brake lining wear control

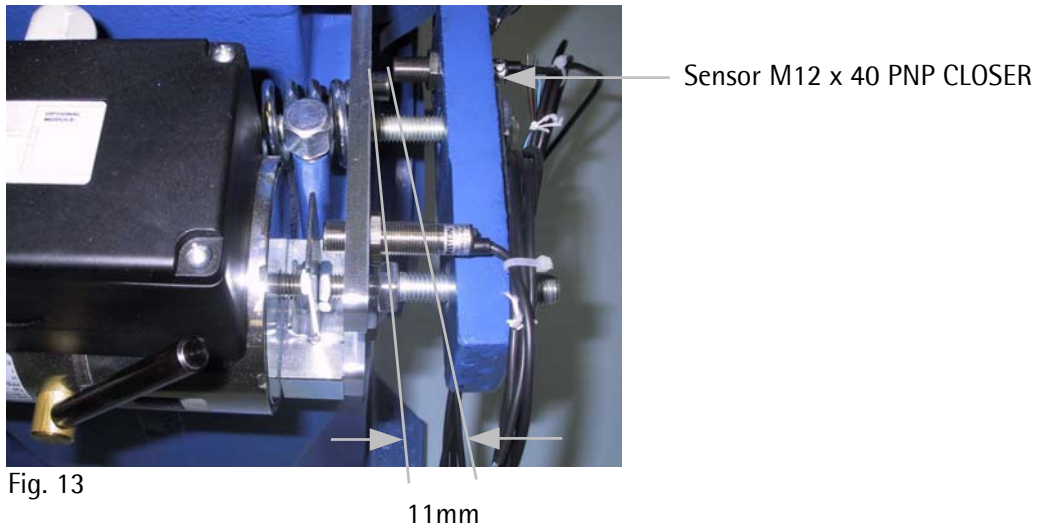

- The sensor for the brake lining wear is fitted in the external drill hole of the brake lever.
- A spacing of 11mm is set for new machines in the factory, and should not be adjusted. The sensor responds, if the brake lining at the front edge of the brake lever has reached a thickness of 1mm. The machine can still be used. The lever must be replaced.
- If it is necessary to replace the two brake linings a distance of 11mm must be set for the new linings.

Information about the inductive brake lining wear sensor:

Design sensing distance: 2.0mm

Initial function – electric circuit by worn brake lining closed

5.10 Adjusting the hood-type switch



Fig. 14

The safety switch on the machine is used to ensure that when the fan hood is raised the machine drive is switched off via the safety chain.
The safety hood-type switch is fitted by OMS in the factory as an option (at request of the customer).



6 MISCELLANEOUS

6.1 Storage

The machine must not be stored outdoors or be exposed to the effects of weather.

A) Storage up to 3 months:

No special storage measures required.

Before installing the machine, please note:

- Check all brake components (remove any slight rust film on the brake drum by braking).
- Rotate the machine by hand (to evenly distribute the grease in the motor bearings).

B) For storage up to 18 months:

If lengthy storage is planned from the outset, this is specified in the order and the machine is conserved by OMS in the factory and is ordered packaged in a moisture repellent (yellow) foil. If this is not the case then:

- The gears must be filled up to the upper locking screw with oil after 6 months storage time at the latest.
- **Attention: oil grade: see yellow adhesive label; only use the same grade oil.**
- After filling with oil the machine must be packaged in a moisture repellent (yellow) foil. (This foil can be ordered from OMS)
- Otherwise: Store in a dry place

Before installing the machine, please note:

- **Reduce the oil level!** Drain the oil to the specified level (see Section 5.1.1)
- Check all the brake components (remove any slight rust film on the brake drum by braking).
- Rotate the machine by hand (to evenly distribute the grease in the motor bearings).
- Install the machine (see Section 4. Commissioning)

C) Storage period longer than 18 months:

As an option, have the machine conserved in the factory or carry out the measures described under: **B) up to 18 months storage time**
Otherwise: store in a dry place

Important, please note before installing the machine:

- Completely replace the gear oil! Check the oil grade and filled level (see Section 5.1.1 and 5.1.3)
- Check all the brake components (remove any slight rust film on the brake drum by braking).
- Rotate the machine by hand (to evenly distribute the grease in the motor bearings).
- If the machine moves stiffly when rotated, the motor bearings might have to be replaced.
- Install the machine (see Section 4. Commissioning)



If the machine is stored for a long time, the manufacturer's guarantee may well expire. If a further guarantee is required, the machine can be returned to the manufacturer for an overhaul, which will be charged for (possible replacement of the bearings, etc.) and for the above measures to be carried out.

6.2 Transport

The machine must be sealed oil tight!

The machine is sealed oil tight in the factory for transport, or must be resealed, i.e. the dipstick must be removed and replaced by the originally enclosed sealing cap.



7 Appendix

Technical data for the OMS-escalator machine EC 2 - 7

Dimensioned drawing of the OMS-escalator machine EC 2 - 7

Electrical connections

(Sheet C)

Declaration of conformity

(Sheet E)

Please contact us if you have any questions:

**OMS Antriebstechnik OHG
Bahnhofstraße 12
36219 Cornberg**

Tel.: 05650 – 969 – 0

Fax: 05650 – 969 – 100

E-Mail: oms.antrieb@t-online.de

Homepage: www.oms-antrieb.de

(We reserve the right to make changes - Status 02/2003)



Gear :	
input-torque, max. :	T max. = 250 Nm
input speed :	n = 1000, 1200 rpm
efficiency :	$\eta, n = > 96 \%$
starting efficiency :	$\eta, s = > 90 \%$
average oil temperature :	T = 25 - 30 K above ambient temperature
oil operating time up to :	t = 40.000 hrs
toothing:	life time durability
bearing life time:	140.000 hrs
with equivalent loading:	$p_{equiv.} = 0,5$ up to $0,6 * \text{nominal motor power}$
noise pressure level (1000 rpm) :	$L_p = 64 \text{ dB(A)}$ (nominal values, dependent on motor power)
gear ratio :	i = 19,99; 22,42 or 24,02
for escalator speed :	v = 0,5 up to 0,75 m/s
version :	single- and Tandem-Units for chain-driving suitable for driving escalators and travelators
position at machine room :	left side (look from escalator to landing conditions)
Motors:	three phase induction motor, 6- and 8 poles, IP 55, integrated fan, suitable for frequency converter
motor protection :	PTC or bimetal-switch
frequency:	50 Hz or 60 Hz
type :	type 225 vertical
motor-nominal torque :	$T, n =$ to 250 Nm
Brake:	double action safety shoe brake
braking torque :	free adjustable up to $> 2,4 * T, n$
Chain wheel:	
version :	duplex or triplex,
size :	(20A-24A or 20B-24B) (1 1/4", 1 1/2", 1 3/4")
number of teeth :	z = 15 up to 30
Standard :	DIN 8187 / 8188 (ANSI)
Dimension:	see overleaf, total height A according to motor type
Machine Monitoring:	
optional for:	brake function monitor brake lining wear monitor vibration measuring sensor oil: temperature, level
Safety-Sensors :	
optional for:	overspeed / machine reversing (NDR)

(we reverse the right to make changes - Status 02/2003)



<i>OMS</i> Hypodrive		
Version:		EC 2-25
Left-hand version		X
Tandem version		-
Gear transmission ratio		19,99; 22,42; 24,02
Input moment, max.	Nm	250
Dimensions:	mm	
A, max. ***)		975
B		365
C		183
D		610
E1		200
E2		160
F1		371
F2		179
F3		170
F4		130
F5		22
G		460
H, K		Depending on the chaining size
L		171
***) M , A		Depending on the motor size and output

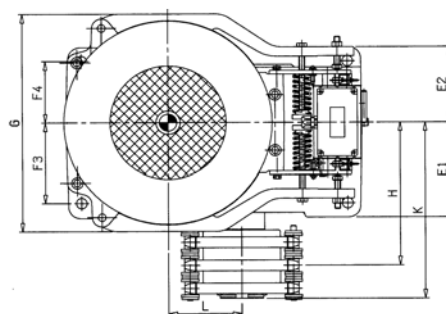
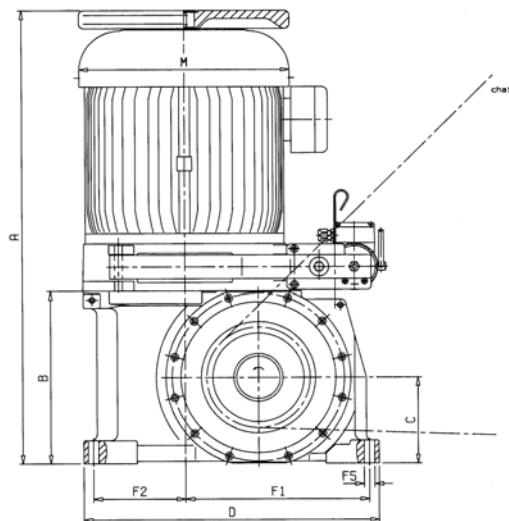



(We reserve the right to make changes - Status 02/2003)

1. Terminal diagram for E - motor

Terminal box:

The machine's motor must be wired for star/delta operation with a 7 way cable (3 + 3 +PE).

2. Mains supply connection for OMS brake magnet

Connection with one control switch;
 Both magnetic circuits are controlled together.

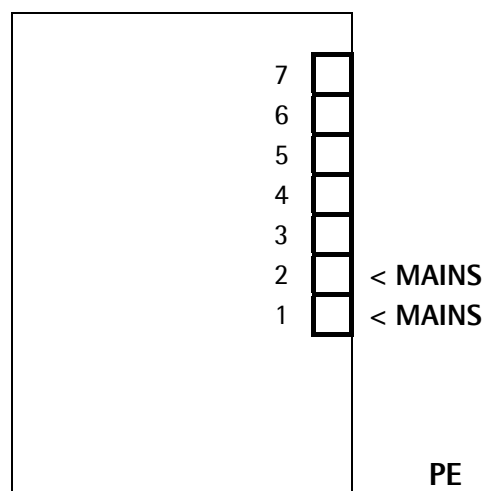

Connection with two control switches;
 Each magnetic circuit is controlled independently.

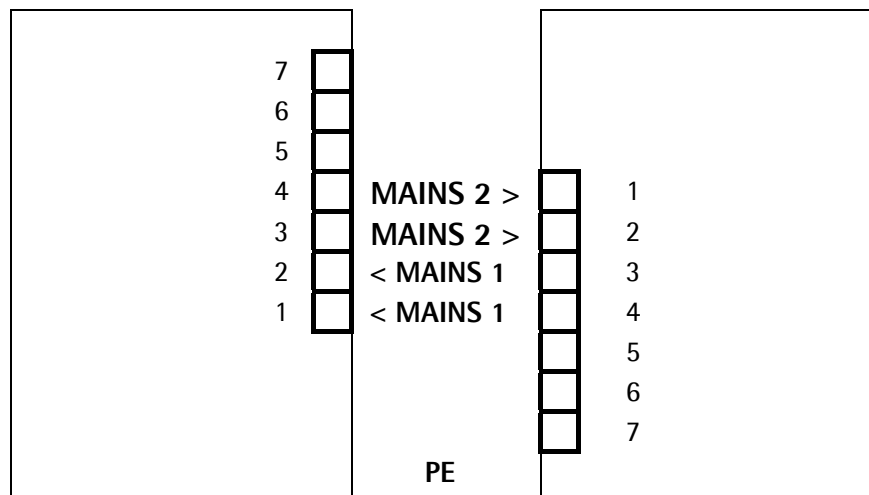



The pin assignment is agreed with the respective customer and is available to the customer accordingly.



(We reserve the right to make changes - Status 02/2003)

Manufacturer's Declaration

for the purposes of the EC Machinery Directive 98/37/EC, Appendix II B
for machines to be installed

Title: Drive unit for escalator and moving pavement
Machine type: EC 2-25
Machine-No.:
Machine data: according to the details given on the rating plate

Consisting of the following individual components:

1. Straight bevel gear pair with hypoid bevel gear stage; (2-stage)
2. Motor; (3-phase ac motor, model 5B S, protection type IP 55, Iso. Cl. F)
3. Brake unit; (circuit safety brake, 2 x brake lever with friction lining, compression spring, rods)
4. Safety installations as an option; (rotational direction control, over-underspeed, brake function, brake lining wear)

Relevant EC Directives:

EG-Machinery Directive 98/37/EG
EG-Low Voltage Directive 73/23/EWG
EG-Directive on Electromagnetic Compatibility 89/336/EWG

We herewith declare that the design and construction of the version of the aforementioned machine delivered by us complies with the relevant fundamental health and safety requirements of the EC Directive and the gears have been designed in compliance with the relevant standards and technical regulations to DIN/ISO.

The machine may only be installed in plant which complies with the provisions of the EC Directive.

Date / Manufacturer's Signature:

.....
.....





SYNTHESO[®] D/EP-Öle

Safety Data Sheet

<p>1.1 Product name: SYNTHESO D a) 68 EP, b) 100 EP, c) 150 EP, d) 220 EP, e) 320 EP, f) 460 EP, g) 680 EP, h) 1000 EP</p> <p>Code-No.: a) 012 060, b) 012 062, c) 012 058, d) 012 056, e) 012 125, f) 012 068, g) 012 083, h) 012 089 16.11.2000</p>
<p>1.2 Klüber Lubrication München KG Emergency telephone no.: Geisenhausenerstraße 7 ++49 - 89 7876 - 0 D-81379 München Tel. ++49 - 89 78 76 - 0 telephone exchange Fax: ++49 - 89 78 76 - 333</p>
<p>2. Composition / information on ingredients Chemical characterization (preparation): Polyalkylene glycol oil</p>
<p>3. Hazards identification No particular hazards known</p>
<p>4. First aid measures After inhalation: Not applicable After contact with skin: Wash off with soap and plenty of water After contact with eyes: Rinse with plenty of water After ingestion: Do not induce vomiting. Obtain medical attention Advice to doctor: Treat symptomatically. If swallowed or in the event of vomiting, risk of product entering the lungs</p>
<p>5. Fire-fighting measures Suitable extinguishing media: Water spray, foam, dry powder, carbon dioxide (CO₂) Unsuitable extinguishing media: High volume water jet Special Hazards: In case of fire the following can be released: Carbon monoxide, hydrocarbons Special protective equipment for firefighters: Standard procedure for chemical fires Additional information: Water mist may be used to cool closed containers. In the event of fire and/or explosion do not breathe fumes</p>
<p>6. Accidental release measures Personal precautions: Risk of slipping due to leakage/spillage of product Environmental precautions: Do not flush into surface water or sanitary sewer system Methods for cleaning up / taking up: Soak up with inert absorbent material (e.g. sand, silica gel, acid binder, universal binder, sawdust). Dispose of absorbed material in accordance with the regulations Additional information: None</p>
<p>7. Handling and storage Advice on safe handling: Avoid formation of aerosol Advice on protection against fire and explosion: No special precautions required Requirements on storage rooms and vessels: No special storage conditions required Incompatible materials: Incompatible with oxidizing agents. Do not store together with food Further information on storage conditions: Store at room temperature in the original container</p>
<p>8. Exposure controls / personal protection Additional advice on system design: Not applicable Ingredients and specific control parameters: None Respiratory protection: No special protective equipment required Hand protection: No special protective equipment required Eye protection: No special protective equipment required Body protection: No special protective equipment required Other protection measures: No special protective equipment required General protection and hygiene measures: Avoid prolonged and/or repeated contact with skin. Clean skin thoroughly after work; apply skin cream. Remove soiled or soaked clothing immediately. Do not inhale aerosol</p>

<p>9. Physical and chemical properties Form: liquid Colour: light yellow Odour: characteristic Pour point: a), b), c) < - 40, d) < - 35, e), f) < - 30, g) < - 25, h) < - 20, °C, DIN ISO 3016 Flash point: > 200 °C, DIN ISO 2592 Ignition temperature: not applicable Lower explosion limit: not applicable Upper explosion limit: not applicable Vapour pressure-first: not applicable Density, approx.: a), b), 1.04, c), d), e), f), g), h) 1.05, g/cm³, 20 °C, DIN 51 757 Water solubility: partly soluble pH value: not applicable Kinematic viscosity, approx.: a) 80, b) 100, c) 155, d) 220, e) 320, f) 460, g) 680, h) 1000, mm²/s, 40 °C, DIN 51 562 Further information: none</p>
<p>10. Stability and reactivity Conditions to avoid: Do not heat above flash point Materials to avoid: Strong oxidizing agents Hazardous decomposition products: None under normal use Additional information: None</p>
<p>11. Toxicological information The toxicological data has been taken from products of similar composition Acute toxicity: LD₅₀/oral/rat = > 2 g/kg (literature data) Chronic toxicity: None Human experience: Prolonged skin contact may cause skin irritation and/or dermatitis</p>
<p>12. Ecological information Information on elimination (persistence and degradability): The product has not been tested Behaviour in environmental compartments: Ecological injuries are not known or expected under normal use Ecotoxic effects: The product has not been tested Additional information: Should not be released into the environment</p>
<p>13. Advice on Disposal Disposal: Dispose of in accordance with your local, state and federal regulations as used oil for incineration Dispose of contaminated packaging and recommended cleaning: Offer rinsed packaging material to local recycling facilities</p>
<p>14. Transport information GGVS / GGVE: not applicable ADN / ADN: not applicable IMDG-Code: not applicable ICAO / IATA-DGR: not applicable Further information: Not classified as dangerous in the meaning of transport regulations</p>
<p>15. Regulatory information Labelling according to EU-guidelines: The product does not require a hazard warning label in accordance with EC-directives/German regulations on dangerous substances National regulations</p>
<p>16. Other information Issue-department of Safety Data Sheet: Chemical Documentation, Tel.: ++49 - 89 7876 - 564</p>

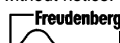
The data in this product information is based on our general experience and knowledge at the time of printing and is intended to give information of possible applications to a reader with technical experience. It constitutes neither an assurance of product properties nor does it release the user from the obligation of performing preliminary tests with the selected product. We recommend contacting our Technical Consulting Staff to discuss your specific application. If required and possible we will be pleased to provide a sample for testing. Klüber products are continually improved. Therefore, Klüber Lubrication reserves the right to change all the technical data in this product information at any time without notice.



Klüber Lubrication München KG, a member of the Freudenberg group